

Industry Trend: APC/AEC 2005 Presentation from Samsung

❖ System Operations Flow Chart

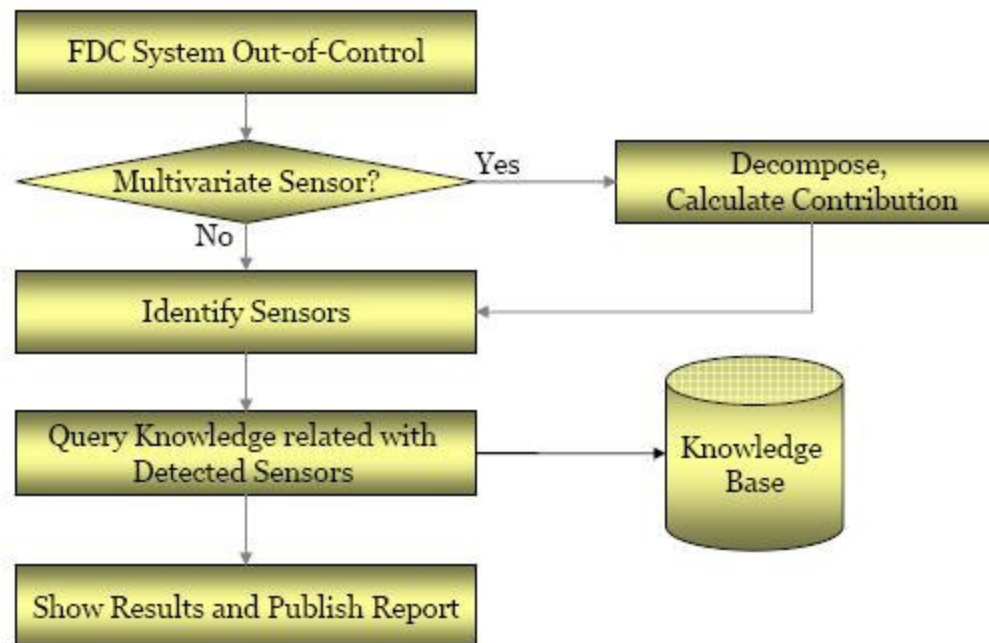

APC/AEC 2005 / Samsung Electronics Co., Ltd. "An Application of Multivariate Statistics in Detecting Equipment Changes" Presenter: Lee, Seungjun

Industry Trend: APC/AEC 2005 Presentation from Samsung

❖ Benefits

- ◆ Reduces the number of monitoring sensors
- ◆ Provides information on which parameter contributes to the alarms
- ◆ Finds the related fault information from database

❖ Future Works

- ◆ More research on multivariate modeling
- ◆ Use of time series filtering for the auto-correlated sensor
- ◆ Development of advanced inference engine of Fault & Parameter Knowledge-base



23/24

APC/AEC 2005 / Samsung Electronics Co., Ltd. "An Application of Multivariate Statistics in Detecting Equipment Changes" Presenter: Lee, Seungjun

Industry Trend: APC/AEC 2005 Presentation from Samsung

❖ Benefits

- ◆ Reduces the number of monitoring sensors
- ◆ Provides information on which parameter contributes to the alarms
- ◆ Finds the related fault information from database

❖ Future Works

- ◆ More research on multivariate modeling
- ◆ Use of time series filtering for the auto-correlated sensor
- ◆ Development of advanced inference engine of Fault & Parameter Knowledge-base

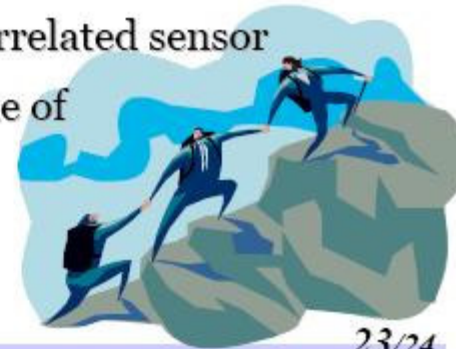

23/24

APC/AEC 2005 / Samsung Electronics Co., Ltd. "An Application of Multivariate Statistics in Detecting Equipment Changes" Presenter: Lee, Seungjun

Industry Trend: APC/AEC 2005 Presentation from Helix Tech. e-Diagnostics Central Data Processing

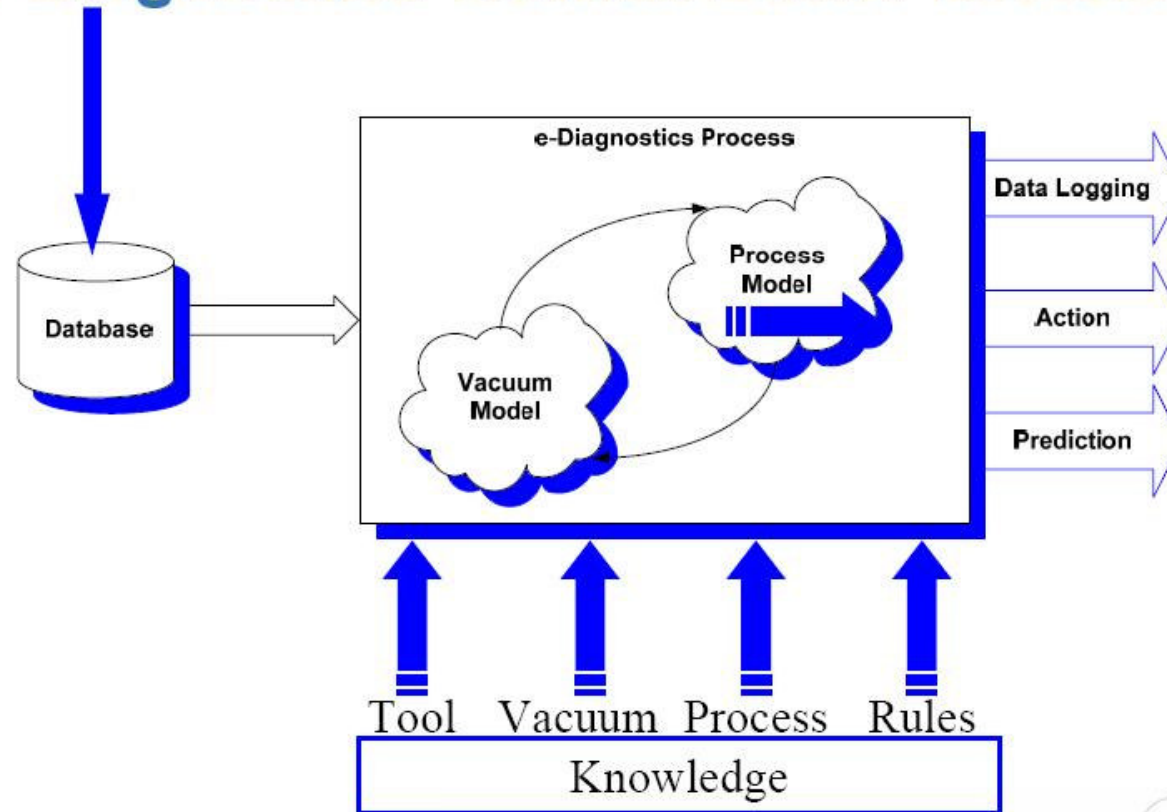

APC/AEC 2005 / Helix Technology Corporation "Predictive Capability Enabled by a Deterministic Method of Analysis or Real World Vacuum System e-Diagnostics" Presenter: Gaudet, Peter

Industry Trend: APC/AEC 2005 Presentation from Helix Tech.

Determining Root Cause of the Leak

- Knowing that there is a leak is not enough
- Time to find leaks is indeterminable
- Must know the source of the leak!
- Automatic determination of the root cause will reduce downtime to a minimum.

APC/AEC 2005 / Helix Technology Corporation "Predictive Capability Enabled by a Deterministic Method of Analysis or Real World Vacuum System e-Diagnostics" Presenter: Gaudet, Peter

Industry Trend: APC/AEC 2005 Presentation from Helix Tech.

Deterministic Method of Analysis

Automated FDC and predictive capability enabled by a deterministic method of analysis.

Use of sensor information to derive physical condition of a vacuum system and components.

The deterministic method provides superior FDC and root cause analysis than statistical and pattern-matching methods for several reasons:

- Definitive understanding is derived from analysis of physical properties and interactions within the vacuum space
- The SW does not have to be trained or calibrated to recognize good and bad process patterns
- There is no requirement for external data such as metrology or yield of previous wafers

APC/AEC 2005 / Helix Technology Corporation "Predictive Capability Enabled by a Deterministic Method of Analysis or Real World Vacuum System e-Diagnostics" Presenter: Gaudet, Peter

Industry Trend: APC/AEC 2005 Presentation from Adventa



Heuristic Modeling?

- ◆ **What rules?**
 - Engineering intuition and experience
 - Data analysis
- ◆ **Which problems?**
 - Scrap
 - Rework
 - Yield
 - Tool efficiency (OEE)
 - Process insight



APC/AEC 2005 / "Reaping the Benefits of Heuristic Fault Modeling" Presenter: Jared Warren, Adventa Control Technologies

Industry Trend: APC/AEC 2005 Presentation from Adventa



Connect the Primitives

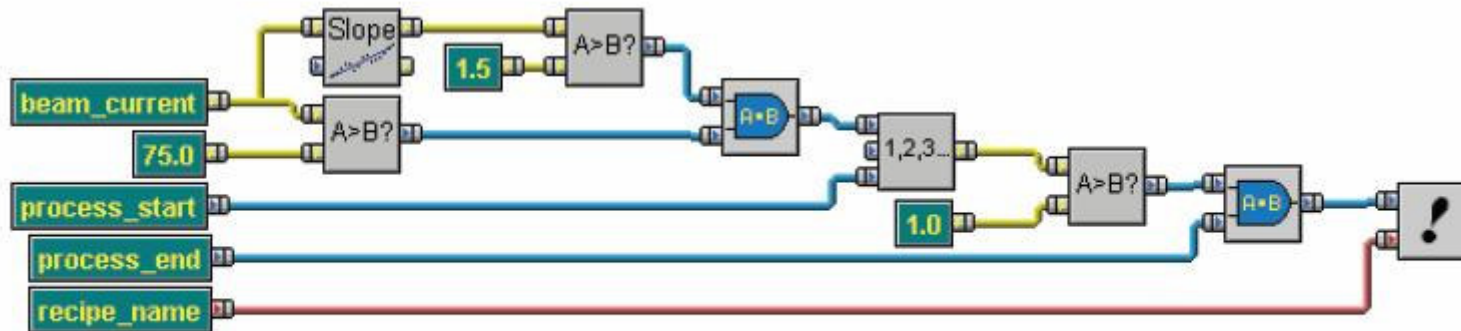

APC/AEC 2005 / "Reaping the Benefits of Heuristic Fault Modeling" Presenter: Jared Warren, Adventa Control Technologies

Industry Trend: APC/AEC 2005 Presentation from Adventa

- ◆ A well defined process is key to reaping the benefits



Write it down!



Map it to primitive operations



Connect primitives to form a model



Perform offline test



Deploy and monitor production

APC/AEC 2005 / "Reaping the Benefits of Heuristic Fault Modeling" Presenter: Jared Warren, Adventa Control Technologies

Industry Trend: Weighted FDC APC/AEC 2005 Presentation from Intel

Weighted FDC

- Weighted FDC integrates engineering knowledge into PCA-based fault detection method
 - To focus on more important parameters, but not completely ignore less important parameters
 - To eliminate the OOC alarms we don't need
 - To have a tighter control on more important parameters
 - To have a looser control on less important parameters

[APC/AEC 2005 / Intel Corporation](#) "Weighted Fault Detection and Classification" Presenter: Mao, John

Industry Trend: Weighted FDC APC/AEC 2005 Presentation from Intel

Benefits

- To eliminate false alarms
- To identify the potential impact to downstream metrology and/or E-Test parameter for any OOC
- Utilize engineering knowledge in FDC to have more accurate detection

[APC/AEC 2005 / Intel Corporation](#) "Weighted Fault Detection and Classification" Presenter: Mao, John